

Fabricated Basket Strainers

BW150 / BW300 - Carbon Steel
BW150SS / BW300SS - Stainless Steel

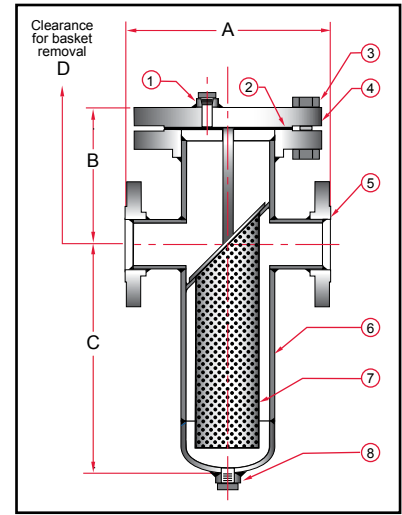

Sure Flow Fabricated Flanged Basket Strainers can be designed to your specific application. Strainers are available in Carbon Steel and Stainless Steel. 2" to 24" pipe sizes in Class 150 and Class 300 are available. ASME flanges are standard, with the capability to supply larger pipe sizes and/or higher ASME pressure ratings. Basket size can be tailored to hold sufficient solids for the required time between clean-outs. Flange sizes can be selected to fit existing piping, or to achieve the required clean pressure drop. Maintenance reducing features include Automatic Flush and Hinged Cover, with or without Davit Assembly.



Notes:

- Higher ASME pressure ratings available
- Larger sizes available

Manufacturer reserves the right to modify dimensions, materials, or design. Consult factory for certification.

		Construction							
Item		1	2	3	4	5	6	7	8
Description		Vent Assembly	Gasket	Bolting	Cover	Inlet / Outlet Flange	Body Assembly	Basket	Drain Assembly

Dimensions (Inches)										
Size			A		B		C		D	
Inches	Prefix	Body	150	300	150	300	150	300	150	300
2	0200	6	14	14	7	9	12	12	23	26
2 1/2	0250	6	15	15	8	9	12 1/2	12 1/2	24	26
3	0300	6	15	15	8	9	12 1/2	12 1/2	24	26
4	0400	8	16	16	8 1/4	9 1/2	14	14	28	28
5	0500	10	16	17 1/2	9 1/2	11	15	15	32	33 1/2
6	0600	10	20	21	9 1/2	11	17	17	34	33 1/2
8	0800	12	22	23	11	14	21	21	41	42 1/2
10	1000	16	32	33	14	14 1/2	25	25	47 1/2	49
12	1200	18	35	36	14 1/2	18	28	28	53	54 1/2
14	1400	20	37	38	15 3/4	19	33	33	61	62 3/4
16	1600	24	42	43	18 1/4	22	36	36	63	69 3/4
18	1800	24	42	43	18 1/4	22	39	36	70	71 3/4
20	2000	30	43	50	23 1/4	28	44	44	82	84 1/2
24	2400	36	52	53	27 1/4	31	60	60	98	106 1/2

Ordering Information

Example: Include full description

Size Model Screen
 (Prefix) Number Opening
0800 BW150SS 125

8" Basket Strainer, Stainless Steel, Class 150 ASME Flanges, 1/8" Perf Screen

Operating Pressures and Temperatures

Type	Size	psi @ Temp Steam	psi @ Temp WOG
BW150	2" - 24"	150 @ 366 °F	285 @ 100 °F
BW150SS	2" - 24"	150 @ 366 °F	275 @ 100 °F
BW300	2" - 24"	300 @ 422 °F	740 @ 100 °F
BW300SS	2" - 24"	300 @ 422 °F	720 @ 100 °F



Sure Flow
 Equipment Inc.

Toll Free: 1-800-263-8251 Toll Free Fax: 1-800-876-1164
 International: 1-905-335-1350 International Fax: 1-905-332-4993
 Email: info@sureflowequipment.com www.sureflowequipment.com

