

Fabricated Basket Strainers

BW600 - Carbon Steel
BW600SS - Stainless Steel

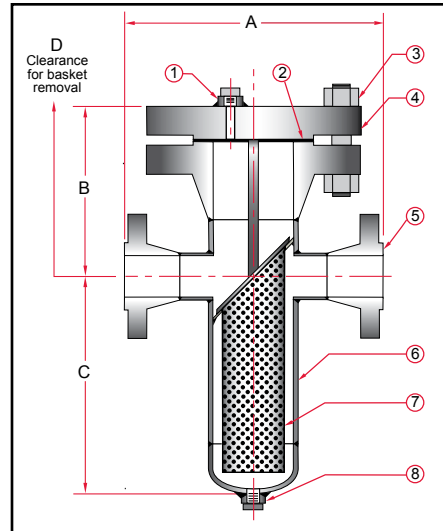

Notes:

- Higher ASME pressure ratings available
- Sizes 8" and up come standard with flat bottom
- Larger sizes available

Manufacturer reserves the right to modify dimensions, materials, or design. Consult factory for certification.

Construction		1	2	3	4	5	6	7	8
Item		1	2	3	4	5	6	7	8
Description		Vent Assembly	Gasket	Bolting	Cover	Inlet / Outlet Flange	Body Assembly	Basket	Drain Assembly

Dimensions (Inches)						
Size			A	B	C	D
Inches	Prefix	Body				
2	0200	6	18 3/8	10 7/16	12	28
2 1/2	0250	6	18 3/8	10 1/2	12	28
3	0300	6	23 7/8	10 3/4	15 3/4	31 1/2
4	0400	8	23 7/8	12 3/16	17 3/8	38
5	0500	8	28	14	17 3/8	40
6	0600	10	29 7/8	14 7/8	21 3/8	42 1/2
8	0800	12	37	15 7/8	23 3/8	50 1/4
10	1000	16	42 1/2	20	27 1/4	57 1/2
12	1200	18	44	22 7/8	30 3/8	66
14	1400	20	46	25	35	72
16	1600	24	54	27 3/4	42 1/4	85
18	1800	24	57	30	47	90 1/2
20	2000	30	60	34	50	98
24	2400	36	68	38	54	112

Ordering Information

Example: Include full description

Size Model Screen
 (Prefix) Number Opening
0400 BW600SS 125

4" Basket Strainer, Stainless Steel, Class 600 ASME Flanges, 1/8" Perf Screen.

Operating Pressures and Temperatures			
Type	Size	psi @ Temp Steam	psi @ Temp WOG
BW600	2" - 24"	600 @ 489 °F	1480 @ 100 °F
BW600SS	2" - 24"	600 @ 489 °F	1440 @ 100 °F



Sure flow
 Equipment Inc.

Toll Free: 1-800-263-8251 Toll Free Fax: 1-800-876-1164
 International: 1-905-335-1350 International Fax: 1-905-332-4993
 Email: info@sureflowequipment.com www.sureflowequipment.com

