

Cast Y Strainers

YF250 - Ductile Iron

Class 250 Flanged End Connections

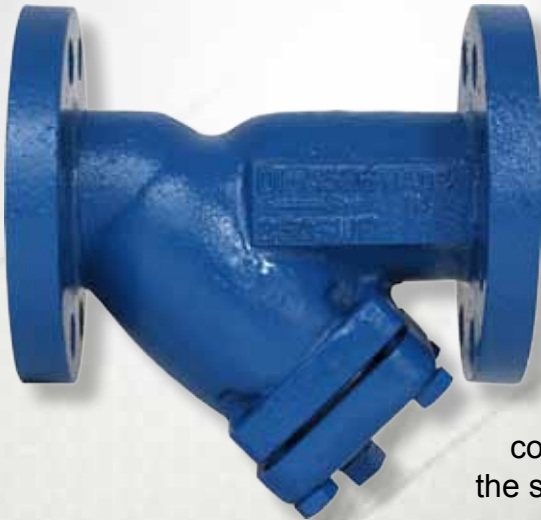

Sure Flow Ductile Iron Flanged Strainers feature a machined seat which ensures a perfect fit for the removable, stainless steel screen. All sizes come complete with flanged blow-off cover, gasket & plug. May be installed in vertical or horizontal pipelines with blow-off connection at the lower end of the screen.

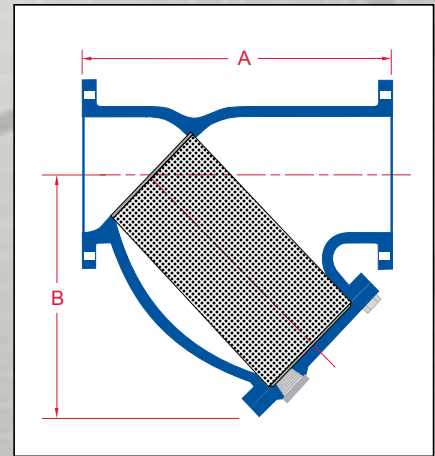

Notes:

- Must specify if for steam service
- Manufacturer reserves the right to modify dimensions, materials, or design. Consult factory for certification.

Construction

Ductile Iron - Body, Cover and Plug
 - ASTM A536 Class 65-45-12
 All screens are Stainless Steel

Dimensions (Inches)					
Size		A	B	Blow-Off NPT	Shipping Weight (LBS)
Inches	Prefix				
2	0200	8 5/8	5 1/4	1/2	34
2 1/2	0250	10 5/8	6 1/2	1	54
3	0300	12	7	1	72
4	0400	14 1/2	8 1/4	1 1/2	114
5	0500	16 3/8	11 1/4	2	174
6	0600	19 5/16	13 1/2	2	204
8	0800	23 3/8	15 1/2	2	432
10	1000	27 3/8	18 1/2	2	660
12	1200	32	21 3/4	2	978

Ordering Information

Example: Include full description

Size Model Screen
 (Prefix) Number Opening
0800 YF250 125

8" Flanged, Y Strainer, Ductile Iron, Class 250
 ASME Flanges, 1/8" Perf Screen

Operating Pressures and Temperatures

Type	Size	psi @ Temp Steam*	psi @ Temp WOG
YF250	2" - 12"	250 @ 400 °F	500 @ 150 °F

Standard Screens

Size	Standard	Opening
2" - 3"	3/64" perf	0.045"
4" - 12"	1/8" perf	0.125"



**Sure Flow
 Equipment Inc.**

Toll Free: 1-800-263-8251 Toll Free Fax: 1-800-876-1164
 International: 1-905-335-1350 International Fax: 1-905-332-4993
 Email: info@sureflowequipment.com www.sureflowequipment.com

