



**Sure flow
Equipment Inc.**



**AUTOMATIC SELF-CLEANING
STRAINERS**

www.sureflowequipment.com

Sure Flow Equipment Inc. features complete custom engineered design and fabrication expertise within a quality focused state-of-the-art manufacturing facility. Commitment to quality, customer satisfaction and continual improvement is integral to our manufacturing processes and ensures custom engineered strainers meet your design specifications and stringent quality requirements. We've made it easy for you to place your order with confidence.

Sure Flow Equipment Inc. provides industry with Custom Engineered Fabricated Strainers to many design codes. Custom products are designed and manufactured to ASME SECTION VIII, DIV 1, Current Edition. ASME "U" Code Stamp and ASME "UM" Code Stamp are available on certain products as specified in this brochure.

The Sure Flow Equipment Inc. list of Certifications includes:

ISO 9001:2015 Certificate of Registration

ASME "U" Code Stamp Certificate of Authorization and (ASME Boiler and Pressure Vessel Code; ASME Section VIII, Div 1, Current Edition);

National Board Certified and authorized to apply the "NB" Mark for pressure vessels and/or pressure retaining items manufactured in accordance with ASME "U" Code Stamp and ASME "UM" Code Stamp;

TSSA Certificate of Authorization (Technical Standards & Safety Authority) for the manufacture of pressure vessels in accordance with ASME Boiler and Pressure Vessel Code, Section VIII, Division 1 and CSA Standard B51, Boiler, Pressure Vessel and Pressure Piping Code.

CE Mark is available

C-TPAT Certified (Customs-Trade Partnership Against Terrorism)

Recognized by PIP (Partners In Protection) for our C-TPAT status

Index

Commitment to Quality	1
Service Applications	1
The Web Automatic Self-Cleaning Strainers - Sequence of Operation	2
The Web Automatic Self-Cleaning Strainers	3
Application and Features	3
Wedge Wire Straining Element - Features and Advantages	3
Straining Element Selection	4
Model Information	4
The Spyder-Clean Automatic Self-Cleaning Strainers	5
Spyder-Clean Advantage	5
Application and Features	5
Specifications / Dimensions / Weights	6 - 7
Specifications and Options	8
The Web Automatic Cast Self-Cleaning Strainers	9
Sequence Controllers	10
Warranty	Back Cover

Service Applications

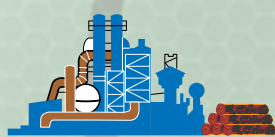

Pulp and Paper



Sewage Treatment Industry

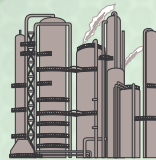

Chemical Plants



Food Processing Facilities



Cement Manufacturing

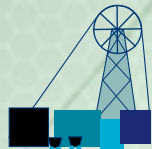

Mining Operations

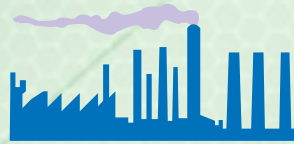

Steel Mills

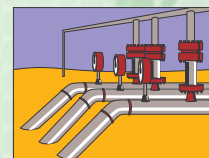

Petrochemical



Sure Flow
Equipment Inc.

Toll Free: 1-800-263-8251 Toll Free Fax: 1-800-876-1164
International: 1-905-335-1350 International Fax: 1-905-332-4993
Email: info@sureflowequipment.com www.sureflowequipment.com

The Web Automatic Self-Cleaning Strainers

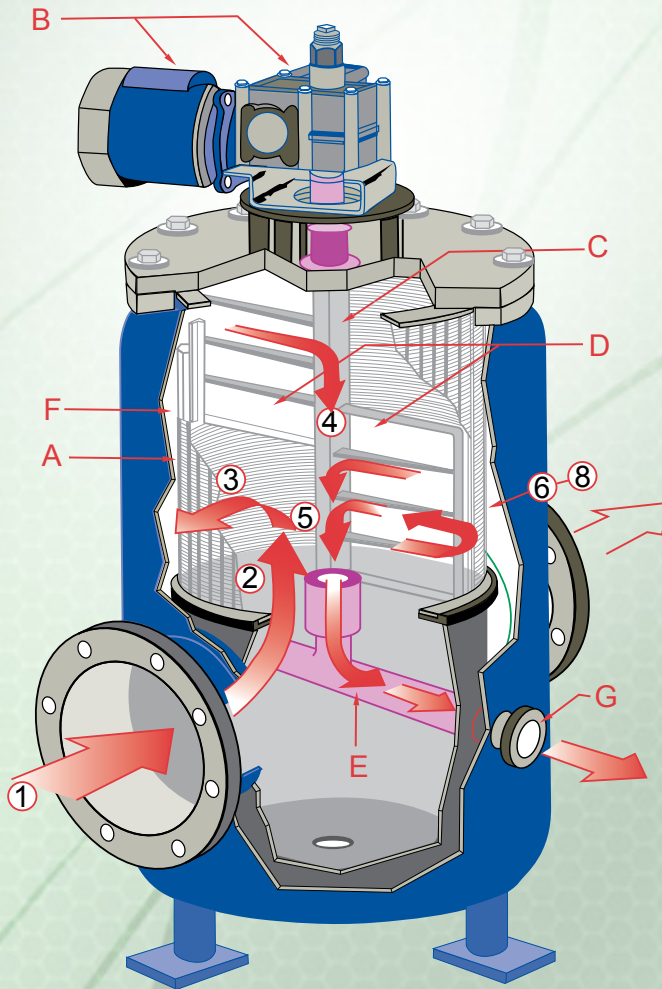
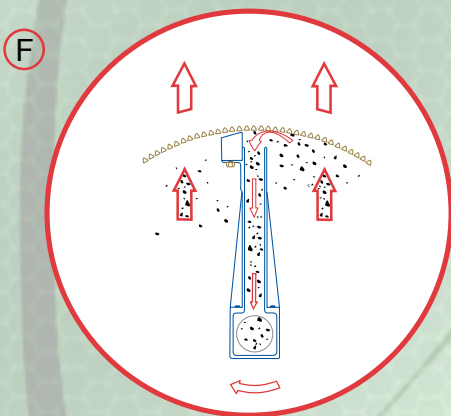

Figure 1 - Cut-away of Web showing fluid flow during operation



Port/straining element interface during backwashing cycle.

The Web

The Web, Motorized, Automatic, Self-Cleaning Strainer, provides continuous debris removal from fluid piping systems that demand full time uninterrupted flow.

The Web is particularly effective in fluid applications where unattended service, high solids loading and/or uninterrupted flow requirements deem a basket strainer and its attendant maintenance problems impractical.

Any of the Model SFA Strainers, applied correctly, will prove efficient and cost effective compared to simplex/duplex strainers or other automatic straining systems.

Sequence of Operation

1. Debris laden fluid enters through inlet to inner chamber. (Fig. 1)
2. Dirty fluid flows upward and outward through the strainer element (A).
3. Debris is retained on the flat face of the strainer element, while strained fluid continues to outer chamber and exits through strainer outlet. (See inset)
4. During backwash or cleaning cycle, the motor/gear reducer (B) is engaged and drives the hollow drive shaft (C) and hollow port (D) around the inner circumference of the strainer element.
5. The backwash assembly C, D, and E are opened to atmospheric pressure by opening the backwash control valve (not shown).
6. Flow reversal occurs at the port/straining element (F) interface because of the pressure differential described in 5. (See Inset)
7. Debris is effectively vacuumed from the full length of the straining element by a vigorous reverse fluid flow and into the hollow port; down the hollow drive shaft and out the backwash outlet (G).
8. The hollow port continues to sweep the full length of the strainer element until the cleaning cycle has ended.
9. The strainer will provide continuous uninterrupted fluid flow during the cleaning operation.
10. The cleaning cycle can be set for continuous or intermittent backwash.



Sure flow
Equipment Inc.

Toll Free: 1-800-263-8251 Toll Free Fax: 1-800-876-1164
International: 1-905-335-1350 International Fax: 1-905-332-4993
Email: info@sureflowequipment.com www.sureflowequipment.com

The *Web* Automatic Self-Cleaning Strainers

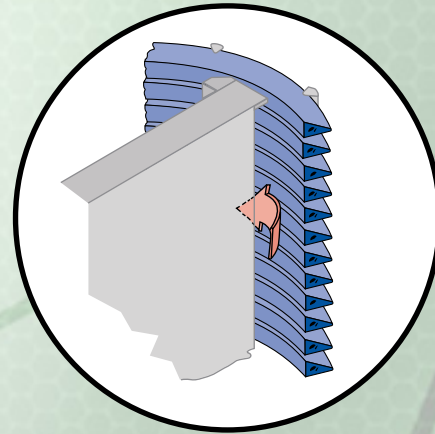

Figure 2 - Wedge Wire Straining Element Cross-Section

Application

The Web's unique strainer element design permits installation in virtually any piping system operating at a positive pressure.

The Web can operate through a wide range of operating pressures (5 psig minimum) and solids loading with effective debris removal and backwashing across the entire pressure range. Additionally, only one drain/backwash connection is required for installation, effectively eliminating the expense of a separate backwash pressure connection.

Strainers are used to protect equipment such as valves, pumps, meters, heat exchangers or spray nozzles, as well as in-feed water and process water applications or virtually any similar application.

The Web Model SFA Automatic Self-Cleaning Strainers are fabricated in pipe sizes ranging from 1" to 48" to suit most application requirements.

Proven Features Include:

- Patented rugged screen and mechanical assist backwash mechanism extends useful service life.
- Unique clog-resistant straining element reduces maintenance downtime.
- Unique adjustable accelerator plate aids cleaning in difficult applications.
- All internal replacement parts supplied in corrosion resistant material.
- Efficient new design reduces maintenance requirements; requires fewer parts.
- Flats for manual operation in case of power failure.
- Low rpm backwash mechanism provides more efficient cleaning, less wear of internals.

Straining Element

The Webs feature a revolutionary reverse rolled wedge-wire straining element (Fig. 2) that is extremely rugged and more clog-resistant than conventional strainer elements that use perforated plate or wire mesh screens.

This proven state-of-the-art straining media is fabricated by wrapping vertical rods with wedge shaped profile wire. Each intersection of rod and wire is welded to produce an extremely rugged one-piece element. This forms a continuous slot that allows only two point contact with debris particles to reduce clogging.

The wedge shaped profile wire reduces the possibility of retaining debris smaller than the screen opening which historically has been the cause of premature clogging or failure of competitive screen designs.

Advantages of Wedge Wire Straining Element

- Maximum effective flow area and maximum operating efficiency are maintained throughout service life.
- Maintenance costs are reduced drastically due to reduced clogging and stapling of fibrous material.
- Long-lived straining element provides reduced operating costs over entire service life.
- Rigid element prevents flexing which can cause premature element failure.
- Efficient, effective debris collection at media/screen interface.



**Sure Flow
Equipment Inc.**

Toll Free: 1-800-263-8251 Toll Free Fax: 1-800-876-1164
International: 1-905-335-1350 International Fax: 1-905-332-4993
Email: info@sureflowequipment.com www.sureflowequipment.com

Straining Element Selection/Model Information



Figure 3 - Wedge-Wire Straining Elements

Straining Element Selection

The Model SFA Straining Element (Fig. 3) is an extremely rugged, single-piece unit available in a variety of standard and custom openings and materials.

Screen opening should be selected based on the amount of protection necessary, and not on the smallest opening available. By specifying a smaller opening than needed, more debris will be retained and subsequently result in longer cleaning durations and increased backwash fluid loss. Also, smaller than necessary screen openings will reduce open screen area and increase pressure loss.

The screen opening should be approximately one-third (1/3) to one half (1/2) the largest size particle that can safely pass downstream. Example: A strainer protecting spray nozzles with a 1/16" orifice would be supplied with a 1/32" screen opening.

Straining Element Selection Guide

Standard				
Slot Opening (Inches)	Fraction Equivalent inches (mm)	Mesh Equivalent	Micron Equivalent	% Open Area
0.003	(0.08)	200	75	9
0.006	(0.15)	100	149	16.5
0.010	(0.25)	50	250	17.5
0.015	1/64 (0.4)	40	385	24
0.020	(0.5)	35	500	30
0.032	1/32 (0.8)	20	795	40
0.062	1/16 (1.6)	10	1590	51
0.125	1/8 (3.2)	6	3205	67
0.187	3/16 (4.8)	4	4795	72
0.250	1/4 (6.4)	3	6410	78

Other slot openings are available upon request.

Standard screen material is 304 Stainless Steel. 316 Stainless Steel, 316L Stainless Steel, Monel and other materials are available upon request.

Model Information

The WEB Base Unit		
Model	Body Material	Size Range
SFA10	Cast Iron	2" - 10"
SFA20	Carbon Steel	1" - 10"
SFA30	Carbon Steel	10" - 36"

The WEB With Spyder-Clean		
Model	Body Material	Size Range
SFA11	Cast Iron	2" - 10"
SFA31	Carbon Steel	1 1/2" - 36"



**Sure Flow
Equipment Inc.**

Toll Free: 1-800-263-8251 Toll Free Fax: 1-800-876-1164
International: 1-905-335-1350 International Fax: 1-905-332-4993
Email: info@sureflowequipment.com www.sureflowequipment.com

The Spyder-Clean Advantage

The Spyder-Clean

The Spyder-Clean is a line of Motorized, Automatic Self-Cleaning Strainers. On fluid piping systems, which demand added cleaning abilities due to application requirements, the Spyder-Clean provides continuous uninterrupted debris removal. It is very effective in system applications where operating pressure is low (under 5 psig) or where the debris is difficult to remove. The Model SFA31 Strainer provides unattended service with the addition of external backwash to enhance the self-cleaning attribute over other automatic strainers.

Application

The Spyder-Clean's unique backwash system permits installation in a broader range of applications. This range includes from relatively low pressure to very high pressure and from coarse, easily removed debris to fine, sticky debris.

In a low pressure mode (such as on the suction side of a pumping system), the Spyder-Clean system is mounted on the leading edge of the strainer backwash arm. External fluid is directed at an incident angle over the inside surface of the straining element through the high pressure nozzle assembly. The high velocity of this spray assists the cleaning of the wedge-wire straining element. **External source backwash pressure must be a minimum of 30 psi over operating pressure.**

Spyder-Clean Strainers are used to protect equipment such as pumps, motors, heat exchangers or spray nozzles, as well as process applications such as cooling towers or virtually any similar application.

The Model SFA31 Spyder-Clean Self-Cleaning Strainers are fabricated in pipe sizes ranging from 1" to 36" to suit most applications' requirements. The Spyder-Clean system can also easily and economically be field installed in any Sure Flow Equipment Self-Cleaning Strainer (6" size and larger) in service as a retrofit installation.

The Unique Spyder-Clean Advantage

The external source of backwash fluid is introduced by opening the control valve (not shown) connecting the spray nozzles (A) at the leading edge (B) of the backwash assembly.

A "Jet" spray action occurs at the straining element inside surface (see insert) in addition to the flow reversal at the port/straining element interface.

Debris is effectively removed from the full-length of the straining element by a vigorous "Spyder-Clean" fluid flow into the hollow port; down the hollow drive shaft and out the backwash outlet.

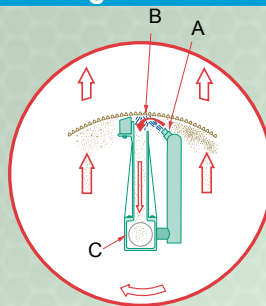

Cross-Sectional View of Port/Straining Element During Backwash Cycle

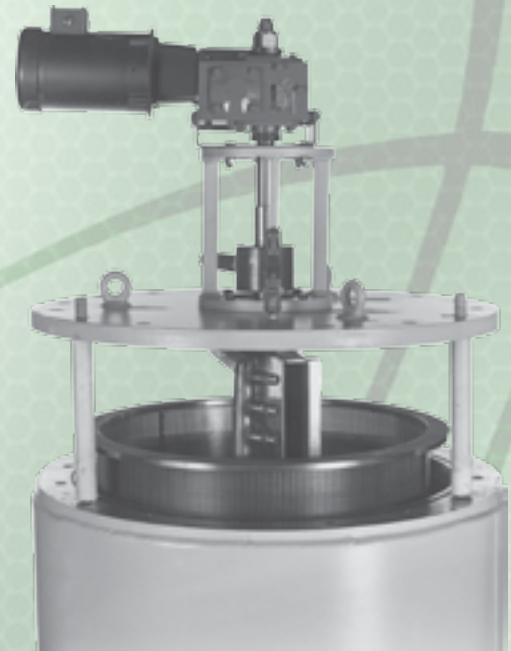

Figure 2 - The innovative internals of the Spyder-Clean showing ease of maintenance.

Proven Features Include

- A unique patented spray assisted/mechanical backwash mechanism for extended service life.
- A clog-resistant straining element (wedge-wire configuration) to reduce maintenance downtime and operator assisted attention.
- All internal replacement parts supplied in corrosion resistant materials (special material available on request).
- An efficient, effective cleaning mechanism which reduces annual maintenance, requiring fewer parts.
- A low rpm backwash cycle provides more efficient cleaning, less wear (no contact between rotating parts) and longer duty cycle on motors and speed reducers.
- Any existing Web (6" and up) can be converted to Spyder-Clean.

The WEB c/w The Spyder-Clean Model SFA31 Automatic Self-Cleaning Strainer Typical Backwash Flow and External Source Requirement

Strainer Size	1", 1-1/2" 2" or 3"	4"	6"	8"	10/12"	14/16"	18/20"	24"	30"	36"
Backwash Line Size	1"	1"	1-1/2"	1-1/2"	2"	3"	3"	4"	4"	6"
Backwash Flow in GPM	8-12	15-20	30-40	60-75	110-150	170-210	250-310	400-490	550-700	750-900
External Backwash Source GPM	10-15	10-15	10-15	10-15	25-35	40-50	50-60	60-70	85-95	115-125
External Line Size	3/4"	3/4"	3/4"	1"	1"	1"	1-1/4"	1-1/2"	1-1/2"	2"



**Sure Flow
Equipment Inc.**

Toll Free: 1-800-263-8251 Toll Free Fax: 1-800-876-1164
International: 1-905-335-1350 International Fax: 1-905-332-4993
Email: info@sureflowequipment.com www.sureflowequipment.com

Specifications / Dimensions / Weights

Model SFA20 & SFA31 1" - 10" Carbon Steel

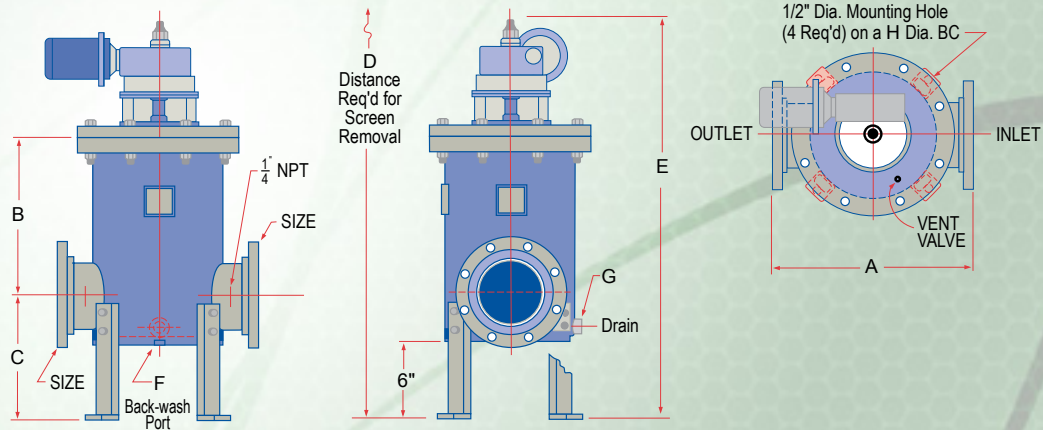

Model No.	Size (in)	A (in)	B (in)	C (in)	D (in)	E (in)	F (in)	G (in)	H (in)	Approx. Wts. (Lbs.)			Motor H.P.
										Dry	Wet	Cov.	
0100-SFA20	1-150	16 1/2	14 1/4	10	59	36 1/2	1 NPT	1 NPT	11 7/8	295	440	130	1/4
0150-SFA20	1 1/2-150	16 1/2	14 1/4	10	59	36 1/2	1 NPT	1 NPT	11 7/8	300	445	130	1/4
0200-SFA20	2-150	16 1/2	14 1/4	10	59	36 1/2	1 NPT	1 NPT	11 7/8	305	450	130	1/4
0250-SFA20	2 1/2-150	16 1/2	14 1/4	10	59	36 1/2	1 NPT	1 NPT	11 7/8	310	455	130	1/4
0300-SFA20	3-150	16 1/2	14 1/4	10	59	36 1/2	1 NPT	1 NPT	11 7/8	315	460	130	1/4
0400-SFA20	4-150	16 1/2	14 1/4	10	59	36 1/2	1 NPT	1 NPT	11 7/8	325	470	130	1/4
0600-SFA20/31	6-150	20	15 5/8	11	65	38	1 1/2 NPT	1 NPT	16	560	750	170	1/4
0800-SFA20/31	8-150	28	18	16	74	46 1/2	1 1/2 NPT	1 NPT	21 1/4	825	1065	180	1/4
1000-SFA20/31	10-150	28	18	16	74	46 1/2	1 1/2 NPT	1 NPT	21 1/4	840	1080	180	1/4

Threaded (NPT) Inlet/Outlet connections available.

Model SFA30 & SFA31 10" - 20" Carbon Steel

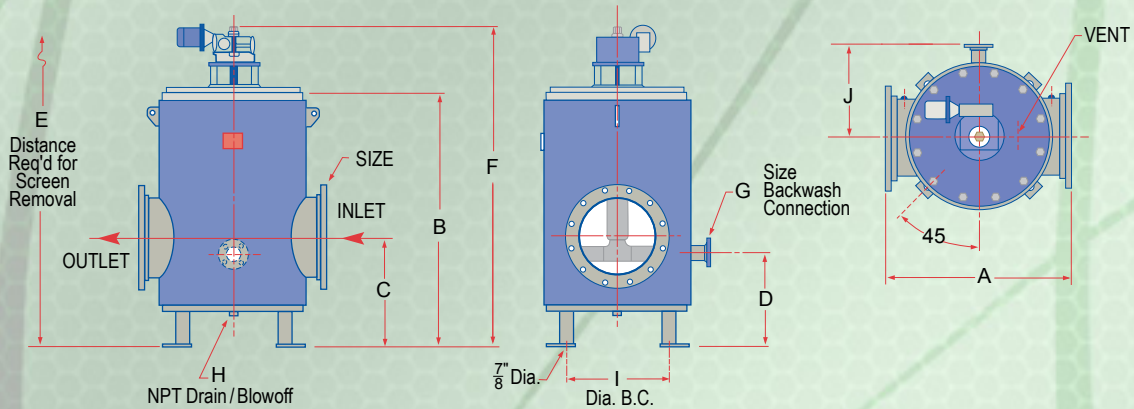

Model No.	Size (in)	A (in)	B (in)	C (in)	D (in)	E (in)	F (in)	G (in)	H (in)	I (in)	J (in)	Approx. Wts. (Lbs.)			Motor H.P.
												Dry	Wet	Cov.	
1000-SFA30/31	10-150	36	43	17 1/2	14 1/2	75	55 1/2	2 NPT	1 1/2 NPT	26	14 3/4	1595	2245	285	1/4
1200-SFA30/31	12-150	36	43	17 1/2	14 1/2	75	55 1/2	2 NPT	1 1/2 NPT	26	14 3/4	1650	2305	285	1/4
1400-SFA30/31	14-150	44	51 1/2	19 1/2	15 1/2	94	69	3-150	1 1/2 NPT	32	21 3/4	2525	3800	510	1/4
1600-SFA30/31	16-150	44	51 1/2	19 1/2	15 1/2	94	69	3-150	1 1/2 NPT	32	21 3/4	2620	3895	510	1/4
1800-SFA30/31	18-150	48	66	24	20 7/8	113	87	3-150	2 NPT	38	25 1/4	3225	5470	700	1/4
2000-SFA30/31	20-150	48	66	24	20 7/8	113	87	3-150	2 NPT	38	25 1/4	3295	5545	700	1/4

Dimensions subject to change without notice. Apply for certified drawings.

Specifications / Dimensions / Weights

Model SFA30 & SFA31

24" - 36"

Carbon Steel

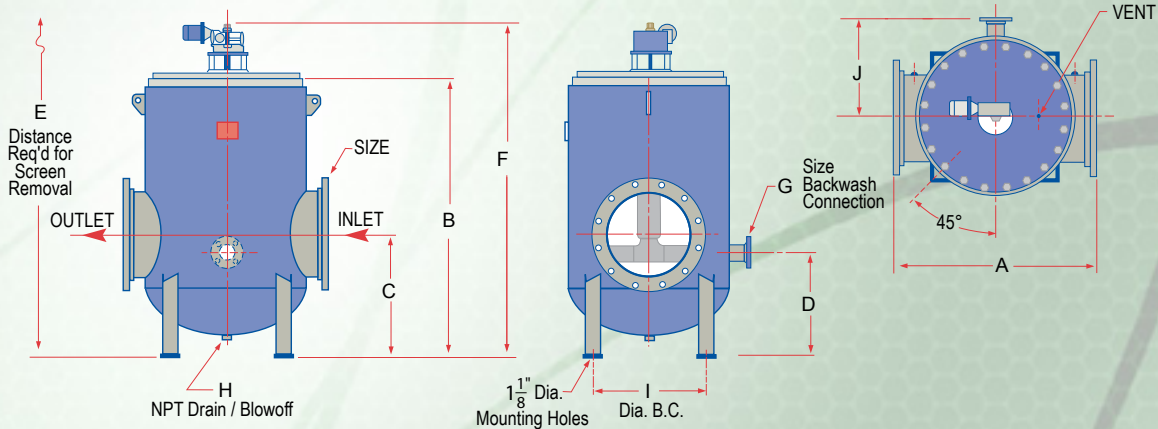

Model No.	Size (in)	A (in)	B (in)	C (in)	D (in)	E (in)	F (in)	G (in)	H (in)	I (in)	J (in)	Approx. Wts. (Lbs.)			Motor H.P.
												Dry	Wet	Cov.	
2400-SFA30/31	24-150	56	77	33	28	122	98	4-150	2 NPT	44	28	4,500	8,475	610	1/3
3000-SFA30/31	30-150	66	94	39	34 1/4	150	115	4-150	2 NPT	54	33	6,525	13,625	1,275	1/3
3600-SFA30/31	36-150	86	120	48	40 1/2	210	132	6-150	2 NPT	72	43	12,050	26,975	1,650	1/2

Larger sizes available upon request. Dimensions subject to change without notice. Apply for certified drawings.

Typical Backwash Flow Requirement

Strainer Size	Model SFA10 / SFA20 (1" - 8")				Model SFA30 (10" - 36")						
	1", 1-1/2" 2" or 3"	4"	6"	8"	10/12"	14/16"	18/20"	24"	30"	36"	
Backwash Line Size	1"	1"	1-1/2"	1-1/2"	2"	3"	3"	4"	4"	6"	
Backwash Flow in GPM	8-12	15-20	30-40	60-75	110-150	170-210	250-310	400-490	550-700	750-900	

Specifications - Pressure Drop Charts

Model SFA30 & SFA31

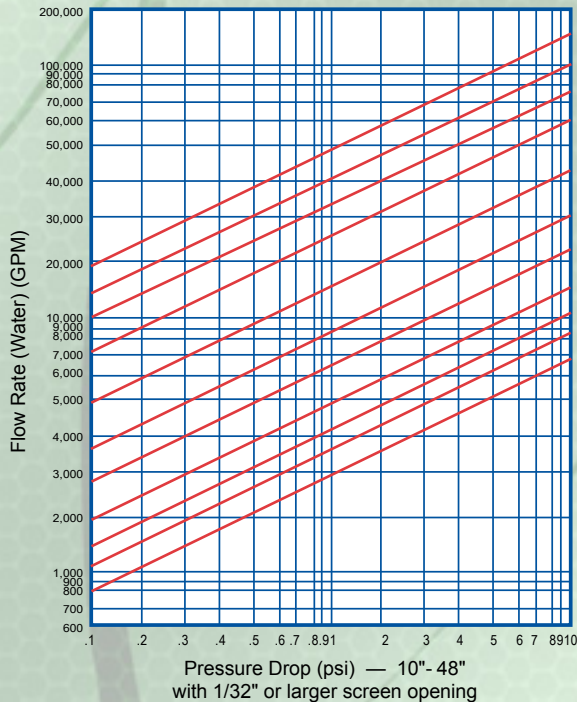

Model SFA20

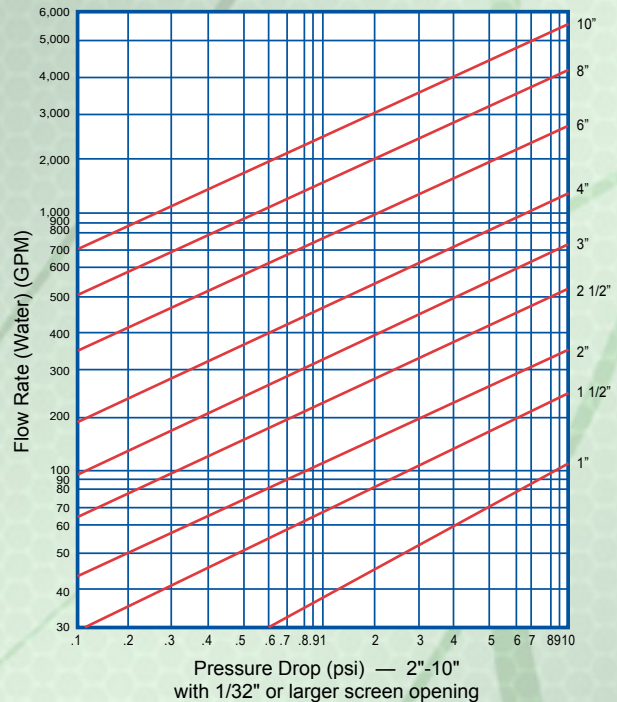

NOTE: These charts are for theoretical calculations ONLY. Please contact our office with your exact specifications and you will be provided with factory calculations.



**Sure Flow
Equipment Inc.**

Toll Free: 1-800-263-8251 Toll Free Fax: 1-800-876-1164
 International: 1-905-335-1350 International Fax: 1-905-332-4993
 Email: info@sureflowequipment.com www.sureflowequipment.com

Specifications and Options

Typical Strainer Specifications

The strainer shall be Model SFA20/SFA30/SFA31 Self-Cleaning, Motorized Type. (Fig. 4)

The body and cover shall be fabricated (carbon steel), designed, manufactured and tested generally to ASME Section VIII Standards, using qualified ASME Section IX welders.

Housing to be suitable for a design pressure of (150) psig. Inlet and outlet connections shall be flanged and conform to ANSI B16.5 standards. The strainer shall have a single backwash connection and drain connections. Unit to be complete with factory supplied steel support legs for bolting to concrete or steel base.

Strainer shall be _____ size capable of handling _____ gpm of fluid at a _____ psig pressure loss with clean straining elements.

The straining element will be manufactured from corrosion resistant (304 Stainless Steel) reverse rolled slotted wedge wire screen designed with _____ inch openings. The wide or flat cross section of the wedge wire shall face the direction of flow providing for a continuous smooth flat surface to trap debris. The straining media shall be free of pockets, tubes, collector bars, etc. that accumulate and trap debris permanently.

All internal parts will be of corrosion resistant (304 Stainless Steel). The strainer shall be provided with drive shaft and hollow port assembly fitted with all necessary bearings and seals.

The drive arm and hollow port assembly including the adjustable accelerator plate will be free running at a maximum speed of two (2) rpm and not contact with screen surface. Port assembly shall be factory and field adjustable for positive effective cleaning and shear capability.

Note: Sizes 1" thru 16" have (1) backwash hollow port. Sizes 18" and up will have (2) backwash hollow ports.

Drive shaft will be supported at the top with roller bearings located in a double reduction gear reducer and at the bottom with a water lubricated guide bearing.

The gear reducer shall be driven by a _____ hp, _____ v, _____ Ph, 50/60 Hz, TEFC motor.



Fig. 4

Strainer Options Available

- | | |
|------------------------------------|--|
| Cover Lift Assemblies - | Recommended for remote locations. |
| ASME - | ASME Section VIII, Division 1. 10 CFR 50 Appendix B. ASME Section II, Class 3. |
| Materials of Construction - | Consult factory for stainless steel, copper, nickel, monel, or other requirements. |
| Control Package - | Control Panel with Nema 4 Enclosure, Backwash Valve with Electric Operator, Single Element Differential Pressure Switch. |
| Design - | High Pressure applications - Consult factory. |
| Spyder-Clean | -Low Pressure and Special Application. |
| Skid Packages - | All equipment desired, including strainers, valves, controls, wiring, piping and skids may be combined as a complete, custom package. Size of the project has no limitation. |



**Sure Flow
Equipment Inc.**

Toll Free: 1-800-263-8251 Toll Free Fax: 1-800-876-1164
International: 1-905-335-1350 International Fax: 1-905-332-4993
Email: info@sureflowequipment.com www.sureflowequipment.com

The Web Automatic Cast Self-Cleaning Strainers



Engineered For Excellence

When Automatic Cast Self-Cleaning Strainers were designed, the priority to make quality and economy inherent in the Model SFA10 Cast Self-Cleaning Strainers was our obligation to meet our customers' growing needs.

Quality

The Automatic Self-Cleaning Strainers have always been meticulously manufactured with quality in mind. The Automatic Model SFA10 Self-Cleaning Strainers will continue that important tradition of providing consistent and trouble-free service. They are designed and constructed to be in compliance with ANSI and ASME Section VIII, Division 1. The ASME Code "U" Stamp is also available.

Model SFA10 & SFA11 2" - 10" Cast Iron

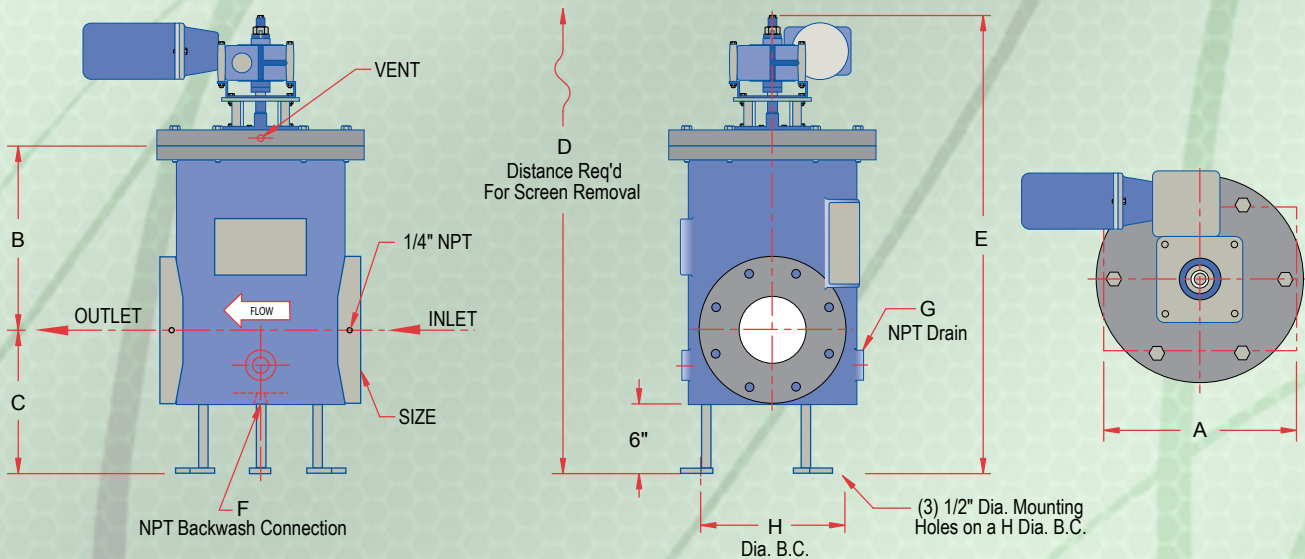

Model No.	Size (in)	A (in)	B (in)	C (in)	D (in)	E (in)	F (in)	G (in)	H (in)	Approximate Wts. (Lbs.)			Motor H.P.
										Dry	Wet	Cover	
0200-SFA10/11	2-125/150FF	23 7/8	14	10 1/2	60	37	1 NPT	1 NPT	13 1/4	370	520	130	1/4
0250-SFA10/11	2 1/2-125/150FF	23 7/8	14	10 1/2	60	37	1 NPT	1 NPT	13 1/4	375	530	130	1/4
0300-SFA10/11	3-125/150FF	23 7/8	14	10 1/2	60	37	1 NPT	1 NPT	13 1/4	380	540	130	1/4
0400-SFA10/11	4-125/150FF	11 7/8	14	10 1/2	60	37	1 NPT	1 NPT	13 1/4	300	425	130	1/4
0600-SFA10/11	6-125/150FF	15 7/8	15 7/8	11 1/2	62	39	1 1/2 NPT	1 NPT	16 1/4	590	690	170	1/4
0800-SFA10/11	8-125/150FF	32 5/8	20 3/4	14	75	47 1/2	1 1/2 NPT	1 NPT	21 1/4	1160	1435	180	1/4
1000-SFA10/11	10-125/150FF	20 5/8	20 3/4	14	75	47 1/2	1 1/2 NPT	1 NPT	21 1/4	875	1120	180	1/4

Dimensions subject to change without notice. Apply for certified drawings.

Sequence Controller

Design and Construction

The Sequence Controller is designed with the Customers' specific requirements in mind. The Sequence Controller provides an automatic, effective backwashing cycle with a minimum loss of water.

The Sequence Controllers are constructed with state-of-the-art industrial type components which permits replacing individual components without having to replace an entire circuit board. The industrial type components are more durable and reliable and adjustments can be made with ease.



Standard Features

- Enclosure - Nema 4
- Adjustable Cycle Timer
- Off-delay Timer
- Motor Starters with Auxiliary contact and overload relay
- Selector Switch
- Indicating Lights
- Fuses
- Terminal Block

Modes of Operation

There are basically two modes of operation - intermittent and continuous. By turning the selector switch, the mode of operation can be selected.

Automatic Intermittent Position

With the selector in the "Auto" position, the drive motor will start and the backwash valve opens as determined by the adjustable cycle timer or by the differential pressure switch.

The differential pressure switch is normally factory set at 1 - 1-1/2 psig over the anticipated clean pressure drop. Should a high differential pressure occur during the timed off period, the differential pressure switch will override the cycle timer and start or continue the backwash until the differential pressure is satisfied.

After the differential pressure has been satisfied, the strainer will continue to backwash for an additional 60 seconds (time delay relay).

The automatic self-cleaning strainer would start a backwash cycle based on the timed sequence selected on the adjustable cycle timer. The timed sequence should be determined by each installation and the conditions experienced. The adjustable cycle timer can be programmed from 15 minutes to a 10-hour cycle (off) and for 1 to 10 minutes duration (on). Adjustments can be made as conditions warrant them. The default factory settings for timers are 2 hours OFF and 2 minutes ON.

Continuous Operation

The selector switch is adjusted to "Manual" thus permitting the continuous mode. In the continuous mode, the automatic self-cleaning strainer will be backwashing continuously with the backwash valve open and the drive motor running. This mode of operation may be necessary if the installation experiences high solid loadings.

In either Mode of Operation, the backwash assembly is specifically designed to rotate at 2 RPM to allow for effective backwashing in less time, thus decreasing the amount of backwash water lost.

Standard Control Package

The Sequence Controller Control Package consists of:

- Control Panel with Nema 4 Enclosure
- Backwash Valve with Electric Operator
- Single Element Differential Pressure Switch

Options

- 230V, 380V, 460V, 575V
- 50 or 60 hertz
- Dual Element Differential Pressure Switch
- Nema 4X (Fibreglass or Stainless Steel), Nema 7 or 9 (Explosion Proof), Nema 12, Nema 3 Enclosures
- Circuit Breakers, Disconnect Switch, Transformer
- Reset Buttons
- Alarms
- PLC Interface and/or Pump Interlock
- Extra Contact and Relays
- Backwash valve can be supplied with Pneumatic Operator
- Backwash Valve available in numerous materials
- Differential Pressure Switches available with Mercury, Snap Action, Diaphragm or piston contacts.

Codes / Standards

The Sequence Controller can be manufactured to UL Listings, CSA Approval, JIC, NEMA Standards.



www.sureflowequipment.com

Sure Flow Equipment Inc. – Limited Warranty

All products are warranted to be free of defects in material and workmanship for a period of one year from the date of shipment, subject to below. **All custom products are not subject to return, credit or refund.**

If the purchaser believes a product to be defective, the purchaser shall:

(a) Notify the manufacturer **within ten(10) days after receipt of merchandise**, state the alleged defect and request permission to return the product. Merchandise will not be accepted for return without a "Return Code" clearly marked on the outside of the package. Contact the office to obtain a return code. **Merchandise will not be accepted for return or credit later than six (6) months after invoicing.**

(b) If permission is given, return the product with the transportation prepaid. Collect shipments will not be accepted. Goods must be returned **prepaid**.

If a shipment is received in a damaged or deficient condition, a claim must be filed with the delivering carrier and noted on the freight bill before you accept the merchandise. All other claims must be made in writing and received by Sure Flow Equipment Inc. within ten (10) days after receipt of merchandise.

If the product is accepted for return and found to be defective, the manufacturer will, at its discretion, either repair or replace the product, F.O.B. factory, within 60 days of receipt, or issue credit for the purchase price.

Sure Flow Equipment Inc. shall not be liable for failure to deliver or delays in delivering occasioned by acts of God, war, labor difficulties, inability to obtain materials or any other causes whatsoever beyond our control.

Other than to repair, replace or credit as described above, purchaser agrees that manufacturer shall not be liable for any loss, costs, expenses, or damages of any kind arising out of the product, its use, installation or replacements, labeling, instructions, information or technical data of any kind, description of product use, sample or model, warnings or lack of any of the foregoing.

NO OTHER WARRANTIES, WRITTEN OR ORAL, EXPRESS OR IMPLIED, INCLUDING THE WARRANTIES OF FITNESS FOR A PARTICULAR PURPOSE AND MERCHANTABILITY, ARE MADE OR AUTHORIZED. NO AFFIRMATION OF ACT, PROMISE, DESCRIPTION OF PRODUCT OR USE OR SAMPLE OR MODEL SHALL CREATE ANY WARRANTY FROM MANUFACTURER, UNLESS SIGNED BY THE PRESIDENT OF MANUFACTURER.

CANCELLATIONS:

Cancelled orders will be subject to a charge of at least 35%.

Cancelled custom orders will be subject to a charge of 100% of quoted price.

SPECIAL DOCUMENTATION: A charge will apply for non-standard, special documentation requests such as Material Test Reports (MTR's) and Certificates of Conformance (COC's).

MINIMUM BILLING: \$100.00 NET

Product shipping weights are approximate and subject to variances depending on packaging methods/requirements.



5010 North Service Rd.
Burlington, ON L7L 5R5
Tel: 905-335-1350 Fax: 905-332-4993



P.O. Box 321
Tonawanda, NY 14151-0321
Tel: 1-800-263-8251 Toll Free Fax: 1-800-876-1164

Email: info@sureflowequipment.com
Web Site: www.sureflowequipment.com

July 2024