



**Sure Flow
Equipment Inc.**

KNIFE GATE VALVES

www.sureflowequipment.com

2012



CONTENTS COMMITMENT TO QUALITY

Table of Contents

Commitment to Quality	1
Service Applications	1
Features	2
Accessories	3
Scavenger Knife Gate Valve	4
How to Order and Manual Valve Dimensional Data	5
Pneumatic Valve Dimensional Data	6
Electric Valve Dimensional Data	7
Technical Information	8
Temperature Charts	9
Bolting Specificatinos	9
Design and Testing	10
Warranty	Back Cover

Commitment to Quality

Sure Flow Equipment Inc. features complete custom engineered design and fabrication expertise within a quality focused state-of-the-art manufacturing facility. Commitment to quality, customer satisfaction and continual improvement is integral to our manufacturing processes and ensures custom engineered strainers meet your design specifications and stringent quality requirements. We've made it easy for you to place your order with confidence.

Sure Flow Equipment Inc. provides industry with Custom Engineered Fabricated Strainers to many design codes. Custom products are designed and manufactured to ASME SECTION VIII, DIV 1, Current Edition. ASME "U" Code Stamp and ASME "UM" Code Stamp are available on certain products as specified in this brochure.

The Sure Flow Equipment Inc. list of Certifications includes:

ISO 9001:2008 Certificate of Registration

**ASME "U" Code Stamp Certificate of Authorization and
ASME "UM" Code Stamp Certificate of Authorization
(ASME Boiler and Pressure Vessel Code; ASME Section VIII, Div 1, Current Edition);**

National Board Certified and authorized to apply the "NB" Mark for pressure vessels and/or pressure retaining items manufactured in accordance with ASME "U" Code Stamp and ASME "UM" Code Stamp;

TSSA (Technical Standards & Safety Authority) Certificate of Authorization for the manufacture of pressure vessels in accordance with ASME Boilers and Pressure Vessel Code, Section VIII, Division 1 and CSA Standard B51, Boiler, Pressure Vessel and Pressure Piping Code.

TSSA (Technical Standards & Safety Authority) Certificate of Authorization for the repair and alteration of boilers, pressure vessels, piping, and Category A, B, E & H fittings in accordance with CSA Standard B51, Boiler, Pressure Vessel and Pressure Piping Code.

CE Mark is available

C-TPAT Certified (Customs-Trade Partnership Against Terrorism)

Recognized by PIP (Partners In Protection) for our C-TPAT status

Member of FCI (Fluid Controls Institute) and Vice Chairman of Pipeline Strainer Section

Service Applications



Sewage Treatment Industry

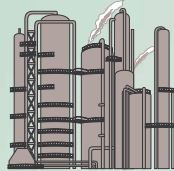

Chemical Plants

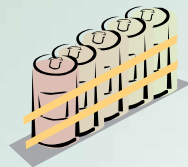

Food Processing Facilities

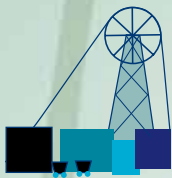

Mining Operations



Cement Manufacturing

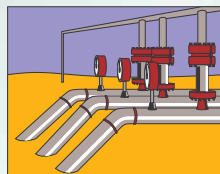

Petrochemical



Steel Mills

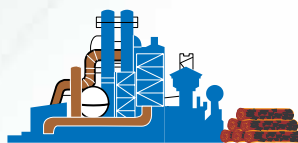

Pulp and Paper



**Sure flow
Equipment Inc.**

Toll Free: 1-800-263-8251 Toll Free Fax: 1-800-876-1164
International: 1-905-335-1350 International Fax: 1-905-332-4993
Email: info@sureflowequipment.com www.sureflowequipment.com

FEATURES

- ▲ Conform to TAPPI TIS 405.8 face-to-face.
- ▲ Tested to MSS SP-81.
- ▲ Full Port.
- ▲ Full lug body drilled and tapped to ASME Class 150.
- ▲ Bi-Directional shut-off resilient seated design.
- ▲ Viton® and EPDM seats available.

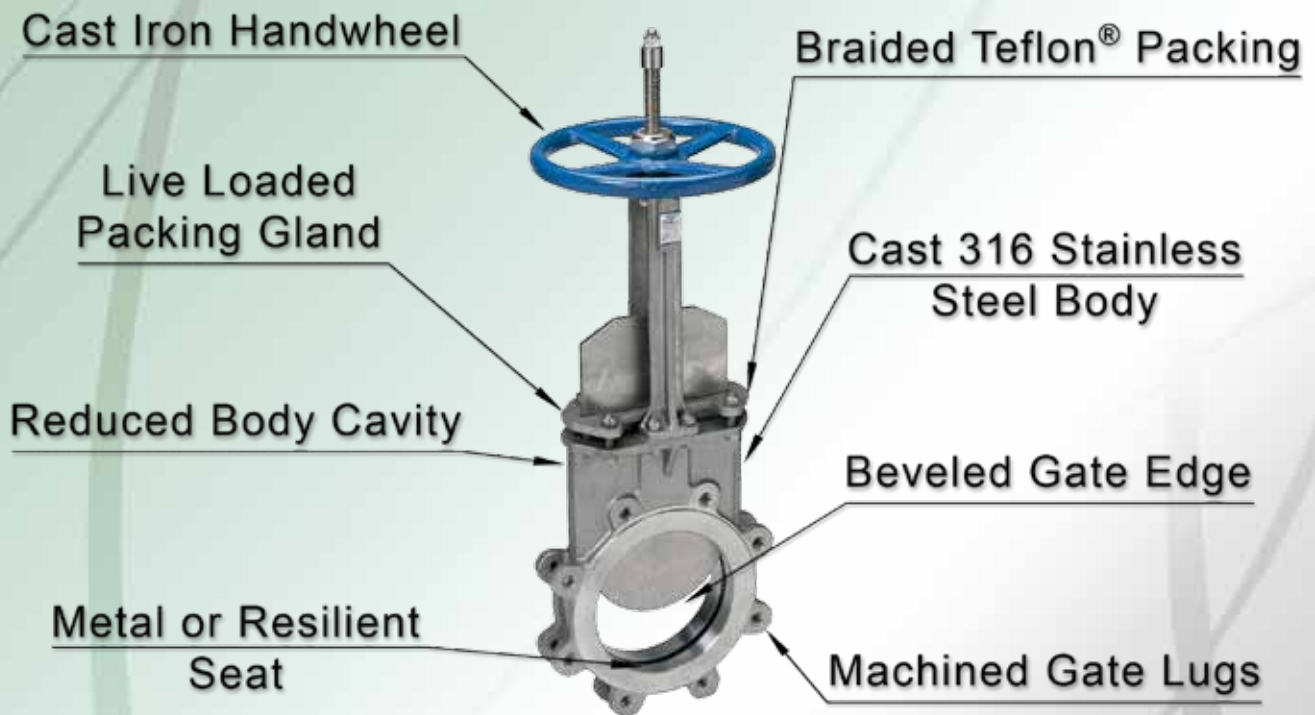

Sure Flow
Equipment Inc.

Toll Free: 1-800-263-8251 Toll Free Fax: 1-800-876-1164
International: 1-905-335-1350 International Fax: 1-905-332-4993
Email: info@sureflowequipment.com www.sureflowequipment.com

ACCESSORIES

Sure Flow Equipment Knife Gate Valves can be automated with **Gear, Electric** or **Pneumatic Actuators** for remote operation. **Chainwheels** or **Floor Stands** can be used for inaccessible areas. When needed, **Lock-Out Devices** can be provided to prevent accidental opening or closing of the valve. **Limit switches** and other accessories can also be provided.



PNEUMATIC ACTUATOR



PROXIMITY LIMIT SWITCHES



GEAR ACTUATOR



CHAINWHEEL

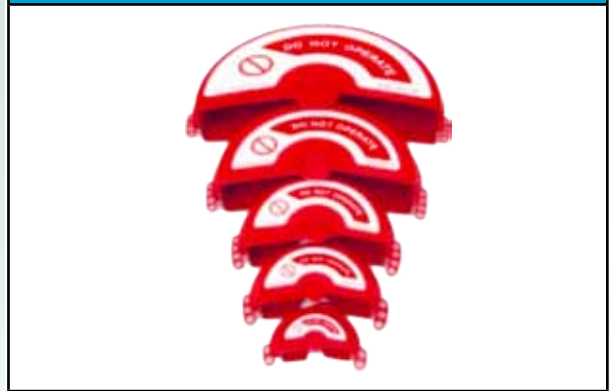

LOCK-OUT DEVICES



FLOOR STAND



ELECTRIC ACTUATOR

SCAVENGER KNIFE GATE VALVE

Features

- ▲ Full port bi-directional shutoff
- ▲ Hardened beveled gate and hardened seat for shearing and sealing
- ▲ Close tolerance machining between bodies
- ▲ Precision ground gate chrome plated
- ▲ Removable insert ring for ease of repair
- ▲ Two piece cavity free body eliminates jamming
- ▲ Four post stainless steel stanchions
- ▲ Live loaded Teflon® packing
- ▲ Adjustable stainless steel packing gland
- ▲ High performance cylinder with safety lock-out system and limit switch brackets
- ▲ Sizes range from 3" to 24" (inquire for larger sizes)
- ▲ Typical applications: OCC recycle, lime mud, liquors, plastics, polymers, cement powder and other slurry and abrasive services



- ▲ Full port conforms to TAPPI
- ▲ Face to Face conforms to TAPPI TIS 405.8
- ▲ Flange ends meet ASME B16.5
- ▲ Full flange drilled and tapped to ASME Class 150 flanges.

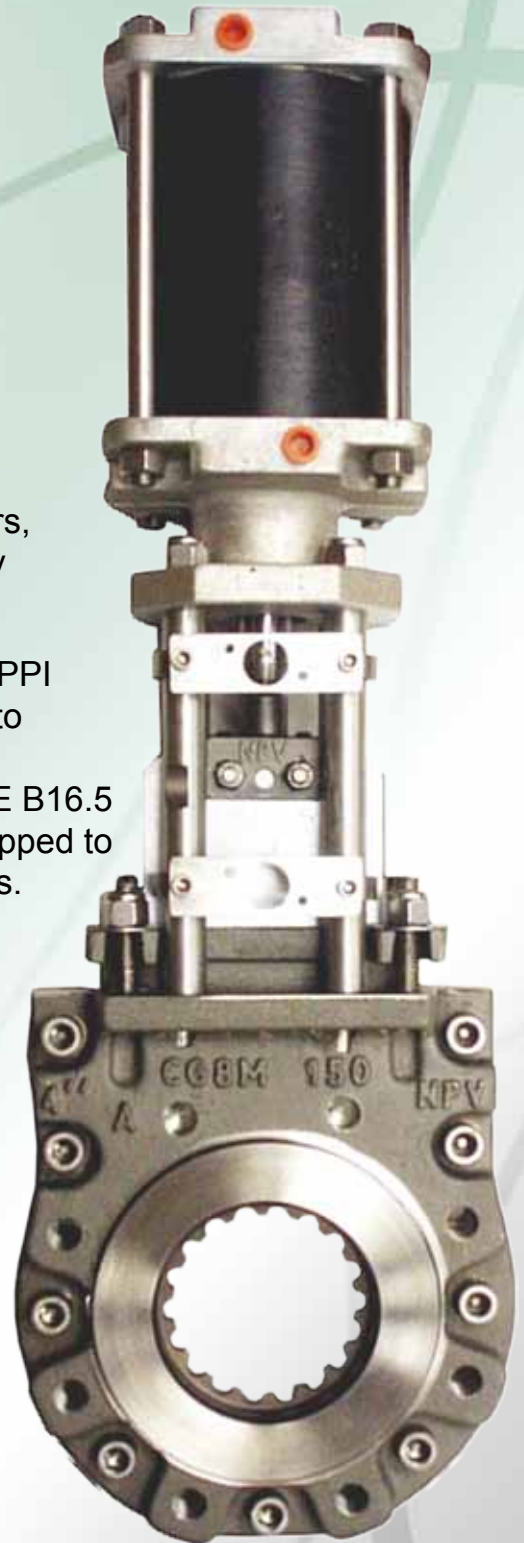

Part Name	Material
Body	CG8M (317 S.S.)
Hardened Insert Ring	Stainless Steel
Hardened Gate	Stainless Steel
Packing Gland	CG8M (317 S.S.)
Packing	Teflon® TFE
Stanchions	303 S.S.
Nuts, Bolts and Studs	18.8 S.S.
O-Ring	Buna
Coupling	CG8M (317 S.S.)
Limit Switch Bracket	N/A
Pneumatic Air Cylinder	N/A



**Sure Flow
Equipment Inc.**

Toll Free: 1-800-263-8251 Toll Free Fax: 1-800-876-1164
 International: 1-905-335-1350 International Fax: 1-905-332-4993
 Email: info@sureflowequipment.com www.sureflowequipment.com

ORDERING INFORMATION

Model **KG150SS**

Example: **0600 / KG150SS / VIR**

6" Stainless Steel Knife Gate Valve, Class 150 with Viton® Seat

Size	0200 - 2" 1400 - 14"	0300 - 3" 1600 - 16"	0400 - 4" 1800 - 18"	0600 - 6" 2000 - 20"	0800 - 8" 2400 - 24"	1000 - 10" 3000 - 30"	1200 - 12"
Seat Material	SSMIR - 316SS SSE - EPDM			SSVIR - Viton® SSS - Silicone			
Actuation	G - Gear		P - Pneumatic			E - Electric	
Accessories	Solenoid, Limit Switch, Chainwheel, Lock-Out Device, Extension Stem, Deflector Cone						

Note: For Scavenger Knife Gate Valve, consult factory with your specifications.

RESILIENT & METAL SEATED

Dimensions (Inches)

Size	2	3	4	5	6	8	10	12	14	16	18	20	24	30	36
A	1 7/8	2	2	2 1/4	2 1/4	2 3/4	2 3/4	3	3	3 1/2	3 1/2	4 1/2	4 1/2	4 1/2	5
B	2	3	3 3/4	4 7/8	5 3/4	7 5/8	9 1/2	11 1/8	13 3/16	15 9/16	17 7/16	19 3/8	23	28 5/16	33 1/2
N (Holes)	4	4	8	8	8	8	12	12	12	16	16	20	20	28	32
H (Tap)	5/8-11	5/8-11	5/8-11	3/4-10	3/4-10	3/4-10	7/8-9	7/8-9	1-8	1-8	1 1/8-7	1 1/8-7	1 1/4-7	1 1/4-7	1 1/2-7
BC	4 3/4	6	7 1/2	8 1/2	9 1/2	11 3/4	14 1/4	17	18 3/4	21 1/4	22 3/4	25	29 1/2	36	42 3/4
C	8	8	8	9	12	12	16	16	18	18	20	24	24	26 3/4	31 1/2
D	11 5/8	13 1/2	15	17	18 1/4	23	28	31 7/8	36 7/8	44 1/2	48 1/4	53 7/8	61	72 1/2	90
D1	13 3/4	17 1/8	20 5/16	22 3/8	25 3/4	32 3/4	40 1/16	46 1/8	52 5/16	60 1/4	67 5/16	75 1/4	85 1/2	106	129

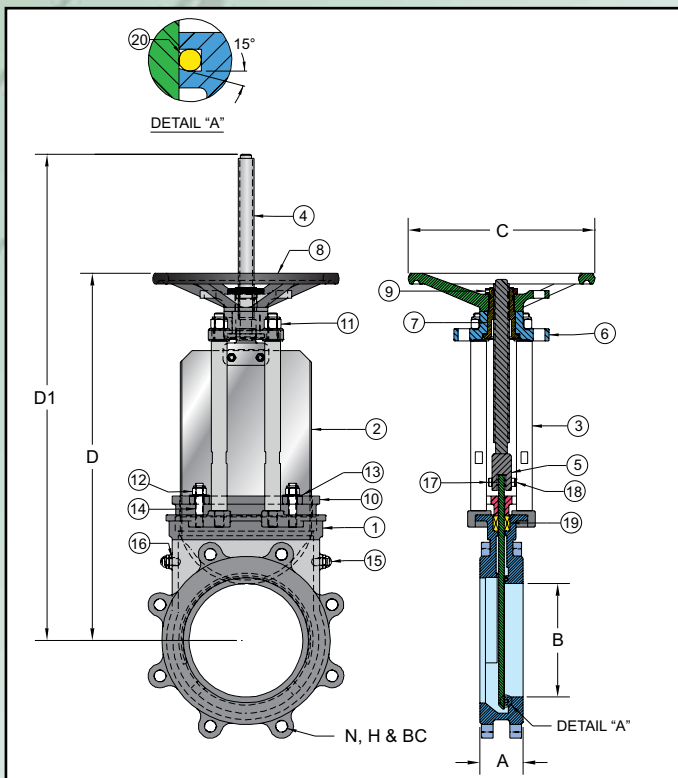

No.	PART NAME	SPECIFICATIONS
1	BODY	SA351 CG8M 317 STAINLESS STEEL
2	GATE	316L STAINLESS STEEL
3	STANCHION	303 STAINLESS STEEL
4	STEM	303 STAINLESS STEEL
5	COUPLING	SA351 CG8M 317 STAINLESS STEEL
6	BRIDGE	ALUMINUM 356
7	YOKE SLEEVE	660 BRONZE
8	HANDWHEEL	ALUMINUM
9	HANDWHEEL NUT	C46400 NAVAL BRASS
10	GLAND	SA351 CG8M 317 STAINLESS STEEL
11	BRIDGE NYLOCK NUT	18.8 STAINLESS STEEL
12	GLAND NYLOCK NUT	18.8 STAINLESS STEEL
13	GLAND WASHER	18.8 STAINLESS STEEL
14	GLAND STUD	18.8 STAINLESS STEEL
15	ACORN NUT	BRASS
16	ALIGNMENT STUD	18.8 STAINLESS STEEL
17	COUPLING BOLT	18.8 STAINLESS STEEL
18	COUPLING NYLOCK NUT	18.8 STAINLESS STEEL
19	PACKING	TEFLON®
20	O-RING	VITON®

PNEUMATIC ACTUATOR

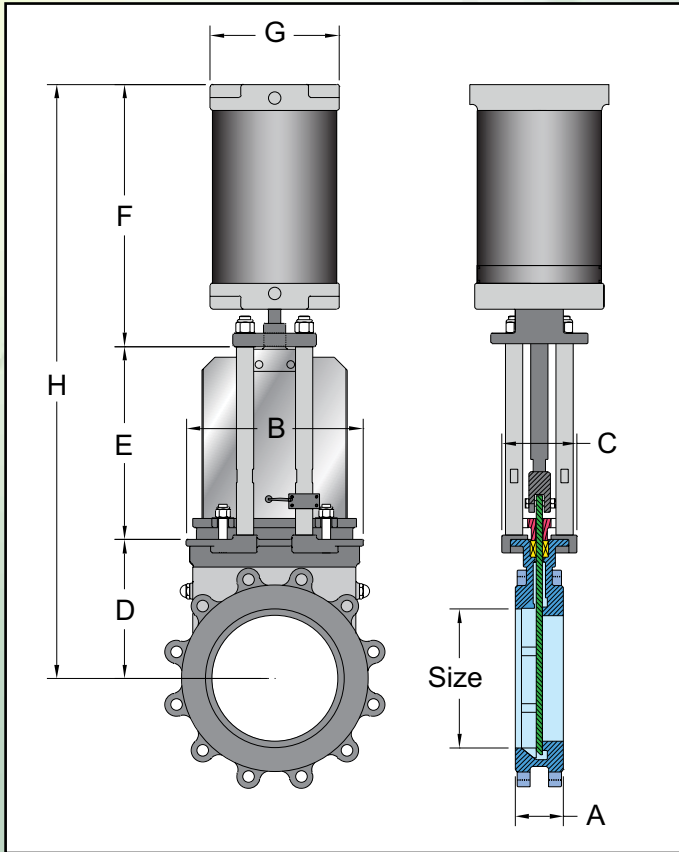

- ▲ The standard pneumatic actuator (double acting on-off cylinder) consists of:
 - Aluminum jacket and covers
 - Stainless steel (AISI 304) piston rod
 - Nitrile coated steel piston
- ▲ Available from 2" to 40"
- ▲ Supply Pressure: minimum 50 psi - maximum 142 psi
- ▲ For valves installed in a horizontal position, we recommend U-type support plates and/or actuator support.
- ▲ Options:
 - Hard anodized jacket and covers
 - Over / Undersized cylinder
 - Stainless steel jacket and covers
 - Manual override
 - Fail safe system
 - Travel stops
- ▲ Instrumentation (on request):
 - Positioners
 - Solenoid valves
 - Flow regulators
 - Air preparation units

Dimensions (Inches)

Size	A	B	C	D	E	F	G	H	Weight (lb.)	Standard Cylinder	Air Connection
2	1 37/64	4 11/16	3 15/16	4 1/8	5 5/64	7	4 17/32	16 7/32	20	C100/62	1/4"
2 1/2	1 37/64	9 9/32	3 15/16	4 33/64	5 3/4	7 19/32	4 17/32	17 7/8	22	C100/77	1/4"
3	1 31/32	5 7/8	3 15/16	4 7/8	6 3/8	8 5/16	4 17/32	19 9/16	24	C100/95	1/4"
4	1 31/32	6 21/32	3 15/16	5 1/2	7 3/8	9 3/32	4 17/32	21 31/32	33	C100/115	1/4"
5	1 31/32	7 5/64	3 15/16	5 29/32	8 19/64	10 43/64	5 1/2	24 7/8	44	C125/143	1/4"
6	2 23/64	8 3/8	3 15/16	6 57/64	9 21/64	11 21/32	5 1/2	27 7/8	55	C125/168	1/4"
8	2 23/64	10 5/16	4 13/16	8 1/16	12 5/32	14 3/32	6 57/64	34 21/34	97	C160/220	1/4"
10	2 3/4	12 33/64	4 13/16	9 27/32	14 21/64	16 55/64	8 21/32	41 1/32	147	C200/270	3/8"
12	2 3/4	14 41/64	4 13/16	11 13/16	16 19/64	18 13/16	8 21/32	46 15/16	180	C200/320	3/8"
14	3 25/32	16 63/64	7 3/5	13 5/16	19 11/16	21 5/8	10 29/32	54 39/64	295	C250/375	3/8"
16	3 15/16	19 9/64	7 3/4	15 7/16	21 21/32	23 37/64	10 29/32	60 43/64	364	C250/425	3/8"
18	4 11/64	21 17/64	10 5/8	17	23 35/64	26 25/32	15 1/32	67 21/64	485	C300/475	1/2"
20	4 21/64	23 45/64	10 5/8	19 3/32	25 29/32	28 3/4	15 1/32	73 3/4	617	C300/525	1/2"
24	4 21/64	27 7/8	10 5/8	23 7/32	29 27/32	32 43/64	15 1/32	85 3/4	728	C300/625	1/2"
28	4 21/64	32 27/32	14 31/32	27	35 7/16	37 51/64	17 31/64	100 15/64	1146	C350/730	3/4"
30	4 21/64	34 13/16	14 31/32	29 59/64	37 13/64	40 5/32	17 31/64	107 9/32	1290	C350/780	3/4"
32	4 21/64	39 31/32	12 19/32	31 9/64	38 7/64	43 7/64	17 31/64	112 23/64	1433	C350/830	3/4"
36	4 21/64	40 61/64	12 19/32	35 15/64	44 1/64	46 21/32	20 17/64	126 7/64	1874	C400/930	3/4"
40	4 21/64	45 9/32	12 19/32	38 25/64	48 15/64	50 19/32	20 17/64	137 13/64	2337	C400/1030	3/4"



**Sure Flow
Equipment Inc.**

Toll Free: 1-800-263-8251 Toll Free Fax: 1-800-876-1164
 International: 1-905-335-1350 International Fax: 1-905-332-4993
 Email: info@sureflowequipment.com www.sureflowequipment.com

ELECTRIC ACTUATOR

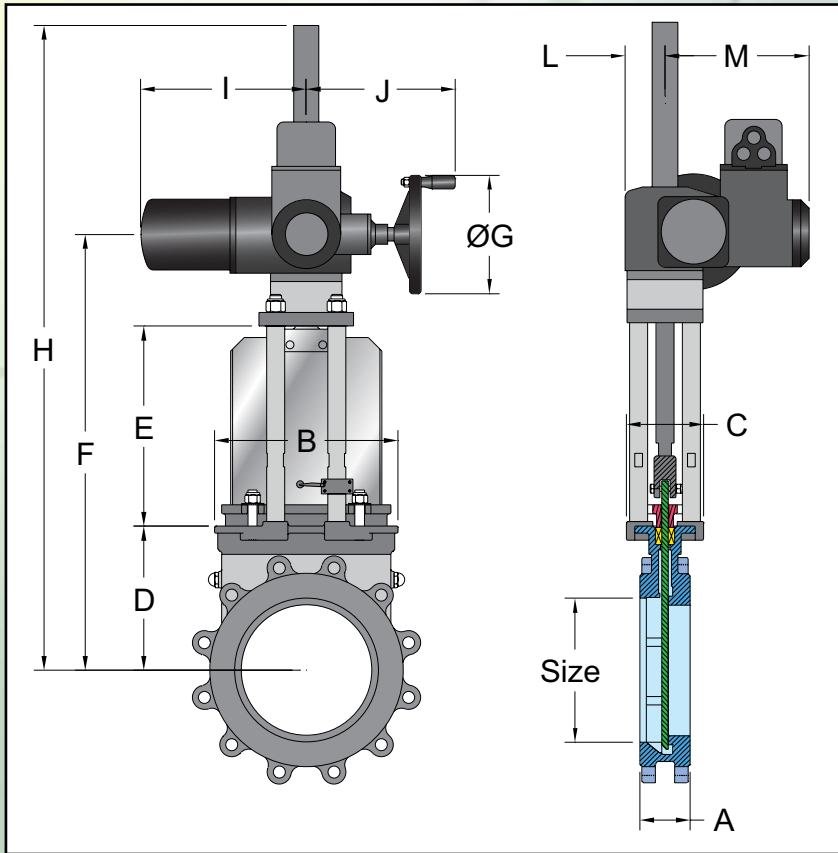

▲ Electric actuator

▲ Rising stem

▲ The standard electric motor is equipped with:
 Manual emergency operation
 Limit switches (open / closed)
 Torque switches

Dimensions (Inches)

Size	A	B	C	D	E	F	ØG	H	I	J	L	M	Torque (lbf-in)
2	1 37/64	4 11/16	3 15/16	4 1/8	5 5/64	14 3/32	6 5/16	21 17/32	10 7/16	9 13/16	2 7/16	9 11/32	177
2 1/2	1 37/64	5 9/32	3 15/16	4 17/32	5 3/4	15 29/32	6 5/16	21 17/32	10 7/16	9 13/16	2 7/16	9 11/32	221
3	1 31/32	5 7/8	3 15/16	4 7/8	6 3/8	16 57/64	6 5/16	23 37/64	10 7/16	9 13/16	2 7/16	9 11/32	265
4	1 31/32	6 21/32	3 15/16	5 33/64	7 25/64	18 1/2	6 5/16	25 13/34	10 7/16	9 13/16	2 7/16	9 11/32	354
5	1 31/32	7 3/32	3 15/16	5 29/32	8 5/16	19 27/32	6 5/16	26 17/32	10 7/16	9 13/16	2 7/16	9 11/32	442
6	2 23/64	8 9/32	3 15/16	6 57/64	9 21/64	21 55/64	6 5/16	44 19/64	10 7/16	9 13/16	2 7/16	9 11/32	531
8	2 23/64	10 5/16	4 13/16	8 5/64	12 5/32	26 21/64	7 7/8	50 3/4	11 7/64	10 5/64	2 7/16	9 23/32	619
10	2 3/4	12 33/64	4 13/16	9 27/32	14 21/64	30 17/64	7 7/8	53 1/8	11 7/64	10 5/64	2 7/16	9 23/32	708
12	2 3/4	14 21/32	4 13/16	11 13/16	16 5/16	34 7/32	7 7/8	57 1/4	11 7/64	10 5/64	2 7/16	9 23/32	796
14	3 25/32	16 31/32	7 3/4	13 5/16	19 11/16	38 7/64	7 7/8	61 9/64	11 7/64	10 5/64	3 23/64	9 23/32	929
16	3 15/16	19 1/8	7 3/4	15 7/16	21 21/32	42 13/64	7 7/8	65 1/4	11 7/64	10 5/64	3 23/64	9 23/32	1062
18	4 11/64	21 1/4	10 5/8	17 1/64	23 35/64	47 7/16	12 13/32	71 1/16	15 5/32	12 25/32	3 35/64	11 7/32	1416
20	4 21/64	23 45/64	10 5/8	19 3/32	25 29/32	51 57/64	12 13/32	75 33/64	15 5/32	12 25/32	3 35/64	11 7/32	1593
24	4 21/64	27 7/8	10 5/8	23 7/32	29 27/32	60 1/32	12 13/32	87 33/64	15 5/32	12 25/32	3 35/64	11 7/32	1859
28	4 21/64	32 53/64	14 31/32	27 1/64	35 7/16	69 13/32	12 13/32	112 1/16	15 5/32	12 25/32	3 35/64	11 7/32	2036
30	4 21/64	34 13/16	14 31/32	29 59/64	37 13/64	74 3/32	15 3/4	116 47/64	15 5/32	13 1/16	3 35/64	11 7/32	2301
32	4 21/64	39 31/32	12 39/64	31 9/64	38 37/64	76 11/16	15 3/4	119 11/32	15 5/32	13 1/16	3 35/64	11 7/32	2567
36	4 21/64	40 15/16	12 39/64	35 1/4	42 51/64	84 59/64	15 3/4	127 9/16	15 5/32	13 1/16	3 35/64	11 7/32	2876
40	4 21/64	45 9/32	12 39/64	38 3/8	47 15/64	92 17/32	15 3/4	135 5/64	15 5/32	13 1/16	3 35/64	11 7/32	3275
48	5 29/32	55 1/8	17 23/32	48 27/64	58 15/32	119 3/32	19 11/16	170 15/32	20 5/64	13 63/64	4 17/32	12 13/64	5753



Sure Flow
 Equipment Inc.

Toll Free: 1-800-263-8251 Toll Free Fax: 1-800-876-1164
 International: 1-905-335-1350 International Fax: 1-905-332-4993
 Email: info@sureflowequipment.com www.sureflowequipment.com

TECHNICAL INFORMATION

Size	Metal Seated Cv	Resilient Seated Cv	No. Turns to Open / Close	Pounds Thrust @ 100 psi
2"	162	131	7	420
2.5"	182	131	8	480
3"	394	316	10.5	650
4"	566	508	12.2	900
5"	958	508	16	1150
6"	1332	1197	18	1400
8"	2343	2046	19.5	2100
10"	2637	3396	24.5	2600
12"	4987	4559	30	3300
14"	7012	6233	53	4200
16"	9744	8986	64	5400
18"	12290	11441	71	6600
20"	15088	14167	79	7850
24"	21317	19949	95	10800

$$C_v = Q \sqrt{\frac{SG}{\Delta P}}$$

Q = Flow (gpm)

SG = Specific Gravity

ΔP = Pressure Drop (psi)



**Sure Flow
Equipment Inc.**

Toll Free: 1-800-263-8251 Toll Free Fax: 1-800-876-1164
 International: 1-905-335-1350 International Fax: 1-905-332-4993
 Email: info@sureflowequipment.com www.sureflowequipment.com

TEMPERATURE CHARTS & BOLTING SPECIFICATIONS

Temperature Charts

SEAT / SEALS

Material	Max. Temp. (°F)	Applications
Metal / Metal	>482	High temperature, Low Tightness
EPDM (E)	248	Acids and non mineral oils
Nitrile (N)	248	Resistance to petroleum products
Viton® (V)	392	General chemical service, High temperature
Silicone (S)	482	Food service, High temperature
PTFE (T)	482	Corrosion Resistance

More details and other materials under request.

PACKING

Material	Max. Temp. (°F)	pH
PTFE Impregn. synth. fibre (ST)	464	2 - 13
Braided PTFE (TH)	500	0 - 14
Graphited (GR)	1112	0 - 14



ASME B16.5 Class 150 Bolting Specifications

Size	K	n°	M	
2"	4 3/4"	4	5/8" UNC	4 - -
2 1/2"	5 1/2"	4	5/8" UNC	4 - -
3"	6"	4	5/8" UNC	4 - -
4"	7 1/2"	8	5/8" UNC	4 - 4
5"	8 1/2"	8	3/4" UNC	4 - 4
6"	9 1/2"	8	3/4" UNC	4 - 4
8"	11 3/4"	8	3/4" UNC	4 - 4
10"	14 1/4"	12	7/8" UNC	6 - 6
12"	17"	12	7/8" UNC	6 - 6
14"	18 3/4"	12	1" UNC	8 - 4
16"	21 1/4"	16	1" UNC	10 - 6
18"	22 3/4"	16	1 1/8" UNC	10 - 6
20"	25"	20	1 1/8" UNC	14 - 6
24"	29 1/2"	20	1 1/4" UNC	14 - 6
28"	34"	28	1 1/4" UNC	20 - 8
30"	36"	28	1 1/4" UNC	20 - 8
32"	38 1/2"	28	1 1/2" UNC	20 - 8
36"	42 3/4"	32	1 1/2" UNC	22 - 10
40"	47 1/4"	36	1 1/2" UNC	26 - 10
48"	56"	44	1 1/2" UNC	28 - 16

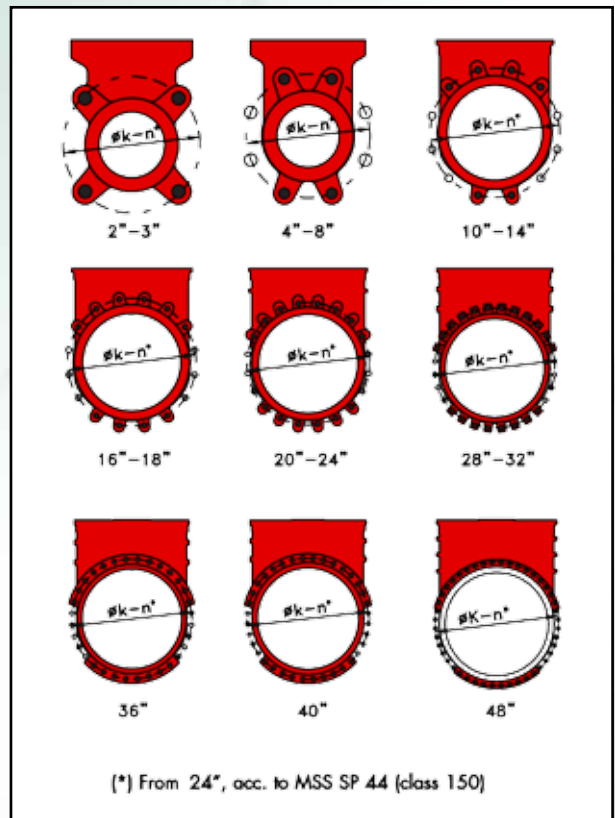

**Sure Flow
Equipment Inc.**

Toll Free: 1-800-263-8251 Toll Free Fax: 1-800-876-1164
 International: 1-905-335-1350 International Fax: 1-905-332-4993
 Email: info@sureflowequipment.com www.sureflowequipment.com

DESIGN & TESTING

MSS SP-81 applies to bonnetless metal seated knife gate valves, 2" to 24" size, 150 psi CWP. Sizes above 24" are not covered under this standard. Additionally, resilient seated knife gate valves and slide knife gate valves are also not covered under MSS SP-81. These products are subject to the individual manufacturer's internal testing & design standard.

Body - MSS SP-81 requires the valve body (pressure vessel and related structure) to be designed for and hydrostatically pressure tested to 1.5 times the rated working pressure.

- Valve rated pressure - 150 psi
- Body test pressure - 225 psi

Gate - MSS SP-81 requires the gate to be designed for and hydrostatically pressure tested to 1.1 times the rated working pressure.

- Valve rated pressure - 150 psi
- Gate test pressure - 165 psi

Seat - MSS SP-81 has an allowable leakage rate (for metal to metal seated valves) of 40 cc per inch of diameter, per minute at 40 psi pressure. On a 12" valve this would be equal to 40 times 12, or 480 cc per minute at 40 psi.

- Maximum allowable leakage of 0.6 GPM when tested with water at 40 psi applied in the normal flow direction.
- No visible leakage when tested with water at 40 psi (for soft seated valves only).

Face to Face - MSS SP-81 has specified face-to-face dimensions and tolerances for each valve size to assure ease of installation for the consumer, regardless of the valve manufacturer.



Sure flow
Equipment Inc.

Toll Free: 1-800-263-8251 Toll Free Fax: 1-800-876-1164
International: 1-905-335-1350 International Fax: 1-905-332-4993
Email: info@sureflowequipment.com www.sureflowequipment.com



www.sureflowequipment.com

Sure Flow Equipment Inc. – Limited Warranty

All products are warranted to be free of defects in material and workmanship for a period of one year from the date of shipment, subject to below. **All custom products are not subject to return, credit or refund.**

If the purchaser believes a product to be defective, the purchaser shall:

- (a) Notify the manufacturer **within ten(10) days after receipt of merchandise**, state the alleged defect and request permission to return the product. Merchandise will not be accepted for return without a "Return Code" clearly marked on the outside of the package. Contact the office to obtain a return code. **Merchandise will not be accepted for return or credit later than six (6) months after invoicing.**
- (b) If permission is given, return the product with the transportation prepaid. Collect shipments will not be accepted. Goods must be returned **prepaid**.

If a shipment is received in a damaged or deficient condition, a claim must be filed with the delivering carrier and noted on the freight bill before you accept the merchandise. All other claims must be made in writing and received by Sure Flow Equipment Inc. within ten (10) days after receipt of merchandise.

If the product is accepted for return and found to be defective, the manufacturer will, at its discretion, either repair or replace the product, F.O.B. factory, within 60 days of receipt, or issue credit for the purchase price.

Sure Flow Equipment Inc. shall not be liable for failure to deliver or delays in delivering occasioned by acts of God, war, labor difficulties, inability to obtain materials or any other causes whatsoever beyond our control.

Other than to repair, replace or credit as described above, purchaser agrees that manufacturer shall not be liable for any loss, costs, expenses, or damages of any kind arising out of the product, its use, installation or replacements, labeling, instructions, information or technical data of any kind, description of product use, sample or model, warnings or lack of any of the foregoing.

NO OTHER WARRANTIES, WRITTEN OR ORAL, EXPRESS OR IMPLIED, INCLUDING THE WARRANTIES OF FITNESS FOR A PARTICULAR PURPOSE AND MERCHANTABILITY, ARE MADE OR AUTHORIZED. NO AFFIRMATION OF ACT, PROMISE, DESCRIPTION OF PRODUCT OR USE OR SAMPLE OR MODEL SHALL CREATE ANY WARRANTY FROM MANUFACTURER, UNLESS SIGNED BY THE PRESIDENT OF MANUFACTURER.

CANCELLATIONS: Cancelled orders will be subject to a charge of at least 35%.
Cancelled custom orders will be subject to a charge of 100% of quoted price.

MINIMUM BILLING: \$100.00 NET

SPECIAL DOCUMENTATION: A charge will apply for non-standard, special documentation requests such as Material Test Reports (MTR's) and Certificates of Conformance (COC's).

Product shipping weights are approximate and subject to variances depending on packaging methods/requirements.



5010 North Service Rd.
Burlington, ON L7L 5R5
Tel: 905-335-1350
Fax: 905-332-4993



P.O. Box 321
Tonawanda, NY 14151-0321
Tel: 1-800-263-8251
Toll Free Fax: 1-800-876-1164

Email: info@sureflowequipment.com
Web Site: www.sureflowequipment.com

View our current catalogues online!
Use your smart phone to scan this QR code and see what else Sure Flow has to offer.

